



Building Guide

Colorado Chapter of the International Code Council

Single Family Residential Uncovered Decks and Porches

How to Use this Guide

Check with your jurisdiction regarding type of submittal (paper or electronic) and for additional requirements. Draw to scale and complete the following (hint: use graph paper with ¼" squares. Example: ¼" = 1').

- 1. Complete this Building Guide** by filling in the blanks on page three, and indicating which construction details will be used.
- 2. Provide Plot Plan** (site plan) showing dimensions of your project or addition and its relationship to existing buildings or structures on the property and the distance to existing property lines drawn to scale. See page 2.
- 3. Fill out a building permit application.**

The majority of permit applications are processed with little delay. The submitted documents will help determine if the project is in compliance with building safety codes, zoning ordinances and other applicable laws.

The Colorado Chapter of the International Code Council is a professional organization seeking to promote the public health, safety and welfare to building construction. We appreciate your feedback and suggestions. please write to the Colorado chapter of the International code Council, P.O.Box 961, Arvada, CO 80001. This building guide can be found on Colorado Chapter of the International Code Council website at: <http://www.coloradochaptericc.org>

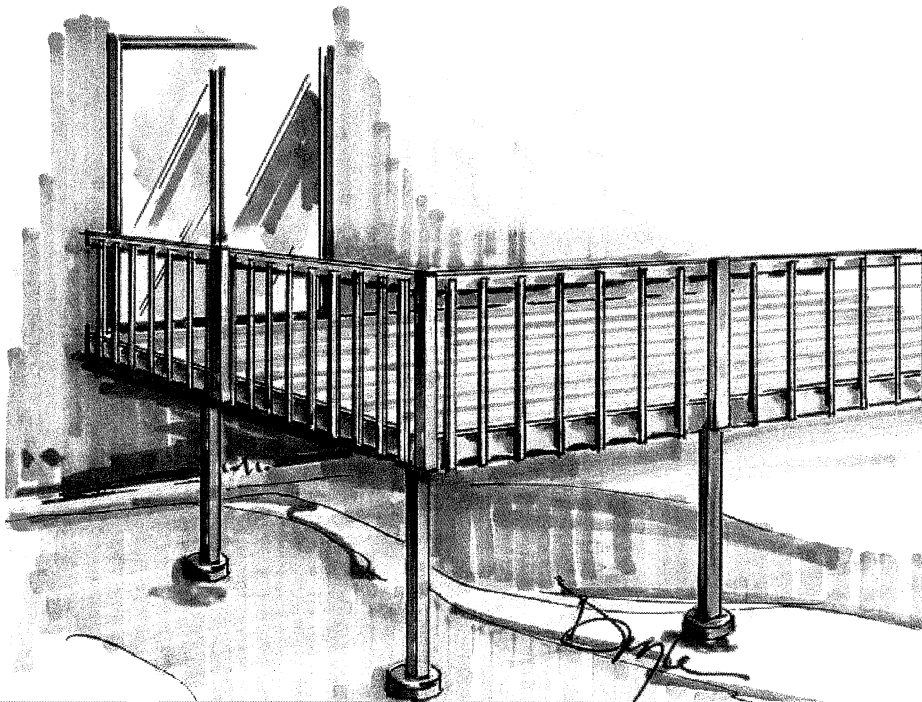

This handout was developed by the Colorado Chapter of the International Code Council as a basic plan submittal under the 2021 International Residential Code. It is not intended to cover all circumstances. Check with your Department of Building Safety for additional requirements.

Single Family Residential Uncovered Decks and Porches

Note: A plot plan (plan view) showing the dimensions of your project or additions and its relationships to existing buildings or structures on the property must be included. In addition to project dimensions, your plot plan must also show other details such as post locations and spacing, joist and beam spans, and any other pertinent information not shown on the section drawing.

Site Plan Example

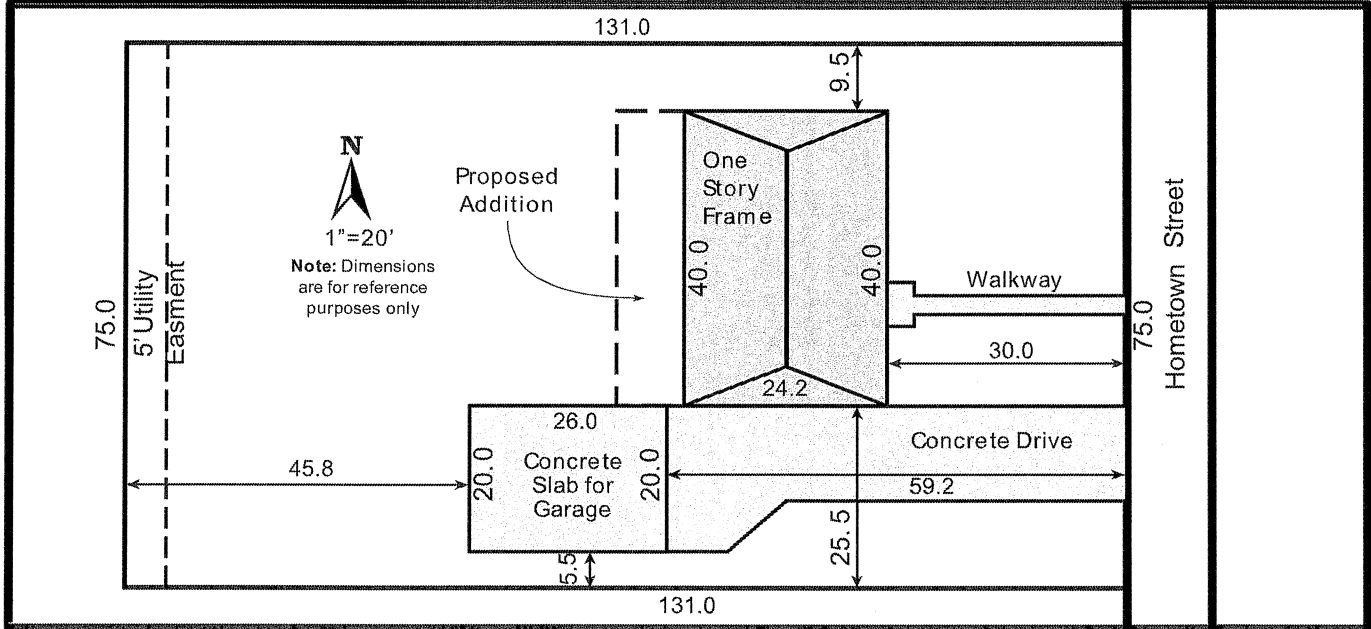

Plan View Example

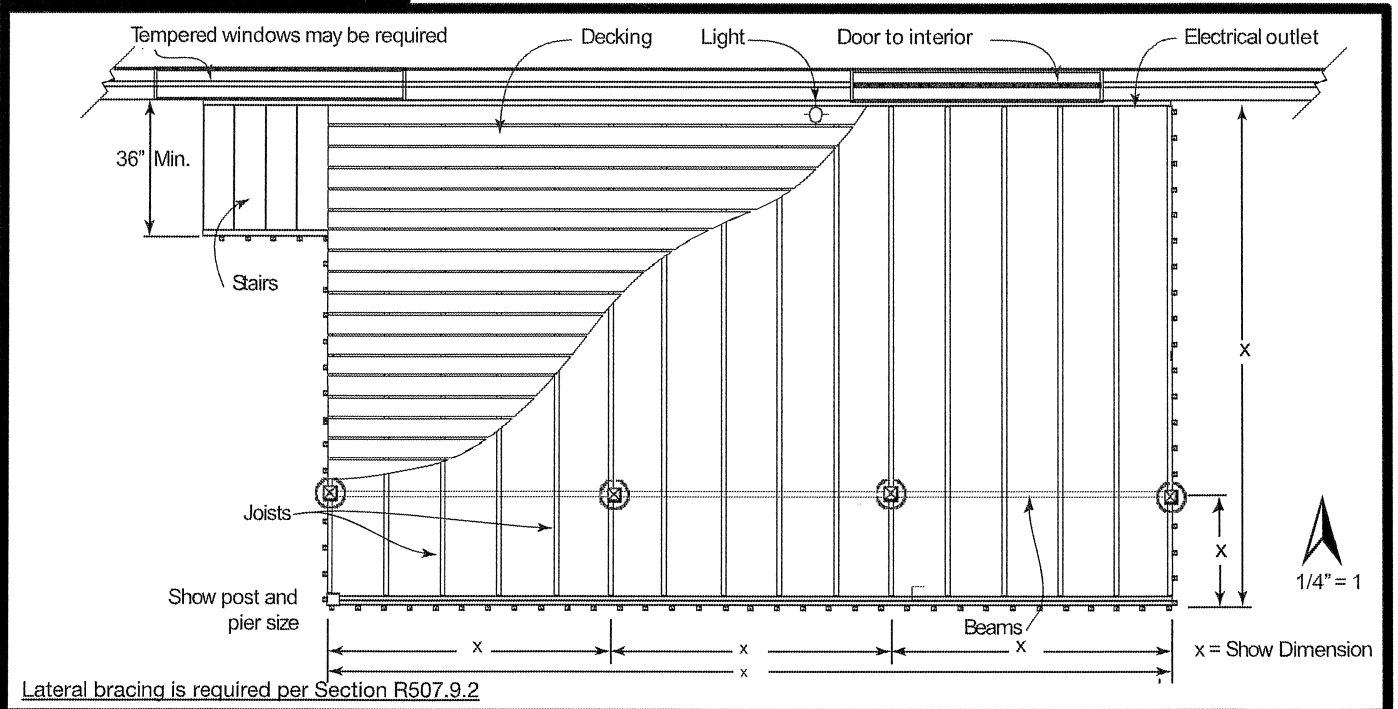

This handout was developed by the Colorado Chapter of the International Code Council as a basic plan submittal under the 2021 International Residential Code. It is not intended to cover all circumstances. Check with your Department of Building Safety for additional requirements.

Single Family Residential Uncovered Decks and Porches

Directions

1. Fill in the blanks. Please print legibly.
2. Indicate in the check box which detail from page 6 will be used.

Address: _____

Deck Section

Size and Spacing of Lag Bolts
 (example: Two rows 1/2" x 4 1/2" lags @ 16" O.C.)
 See Table 1

Type of decking _____ X _____ - _____
 (example: 1 x 4 or 2 x 6 or Trex)

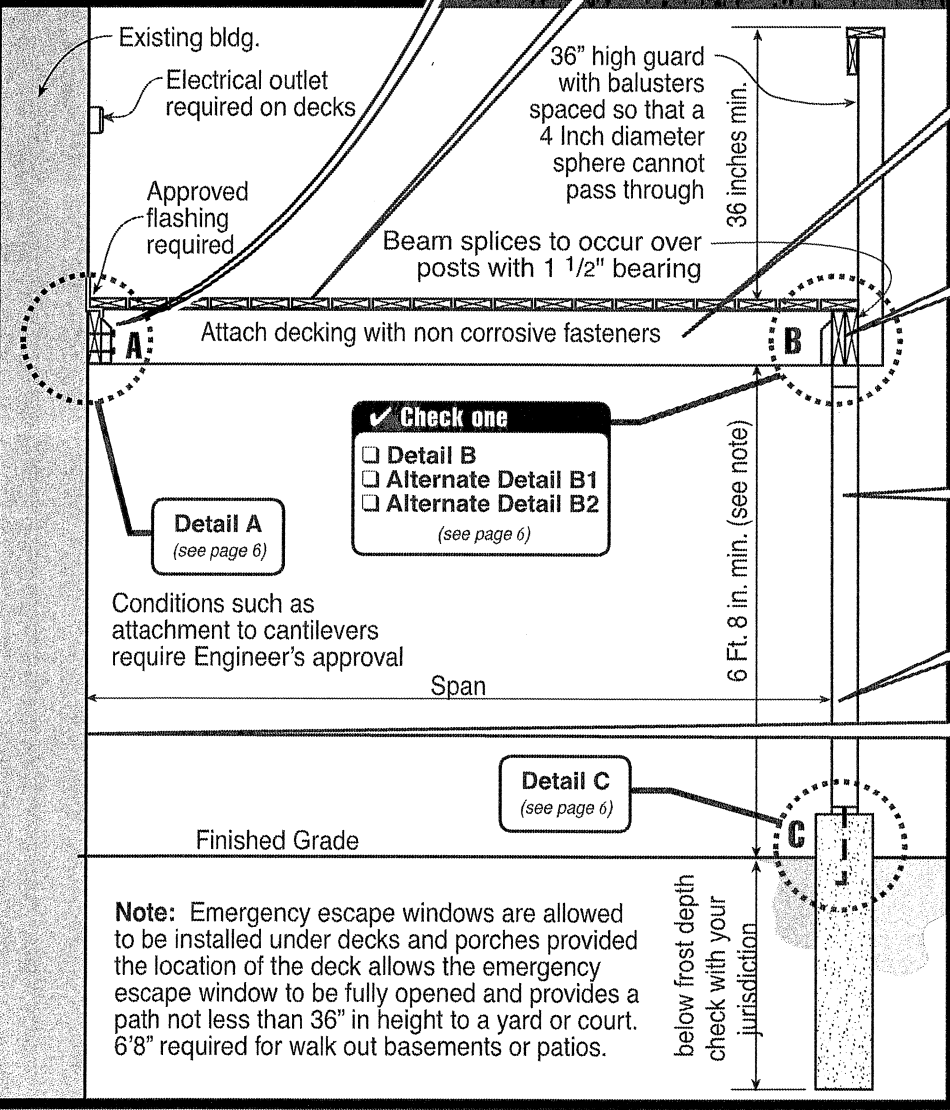

2x _____ joists
 spaced _____ " apart
 (example: 2 x 10" spaced 24" apart) See Table 2

() _____ x _____ beam
 (example: (2) 2 x 10 - see detail B) See Table 3

Wood Species:

 (example: Western Cedar or Southern Yellow Pine)

_____ x _____ posts spaced _____
 apart (example: 4 x 4 posts spaced 8' apart)
 Post height _____ see Table 4

Span _____
 (example: 13' - 4")

Type of exterior wall covering
 (example: siding, brick, stucco)

- Check one
- Detail B
 - Alternate Detail B1
 - Alternate Detail B2
- (see page 6)

Detail A
 (see page 6)

Detail C
 (see page 6)

Note: Emergency escape windows are allowed to be installed under decks and porches provided the location of the deck allows the emergency escape window to be fully opened and provides a path not less than 36" in height to a yard or court. 6'8" required for walk out basements or patios.

below frost depth
 check with your
 jurisdiction

This handout was developed by the Colorado Chapter of the International Code Council as a basic plan submittal under the 2021 International Residential Code. It is not intended to cover all circumstances. Check with your Department of Building Safety for additional requirements.

Single Family Residential Uncovered Decks and Porches

Table 1 Ledger connection

NOTE: Contact your local jurisdiction where snow loads exceed 40 psf.

Ledger Connection to rim joist

Deck live load = 40psf; Snowload = 40psf; Dead load = 10 psf

CONNECTION DETAILS	JOIST SPAN						
	6' and less	6'1" to 8'	8'1" to 10'	10'1" to 12'	12'1" to 14'	14'1" to 16'	16'1" to 18'
On-center spacing of fasteners							
1/2 -inch diameter lag screw with 1/2 -inch maximum sheathing	30	23	18	15	13	11	10
1/2 -inch diameter bolt with 1/2 maximum sheathing	36	36	34	29	24	21	19
1/2 -inch diameter bolt with 1 -inch maximum sheathing	36	36	29	24	21	18	16

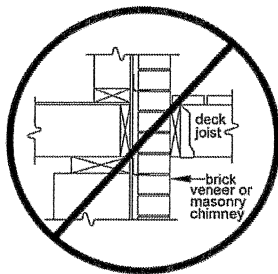

Ledger minimum size 2x8 pressure treated HF, DF or SP #2 or better; shall not be supported by stone or masonry veneer or be attached to a cantilevered floor.

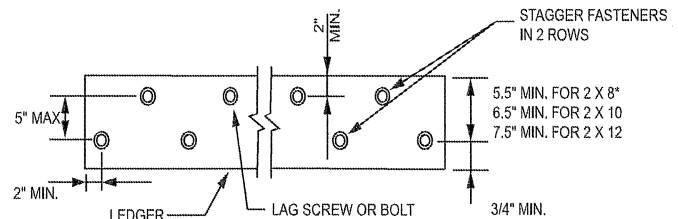
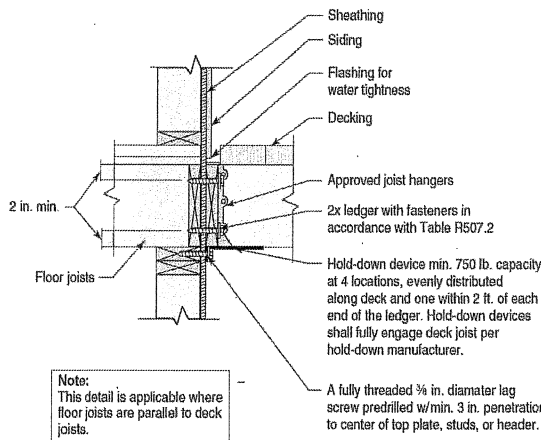
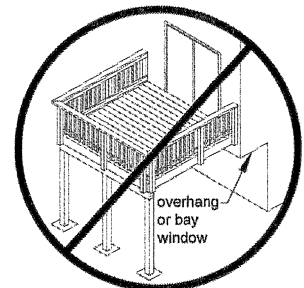

LAGSREWS AND BOLTS LOCATION IN DECK LEDGERS AND RIM JOISTS

MINIMUM END AND EDGE DISTANCES AND SPACING BETWEEN ROWS				
	TOP EDGE	BOTTOM EDGE	ENDS	ROW SPACING
Ledger	2 inches	3/4 inch	2 inches	1 -5/8 inches
Band Joist	3/4 inch	2 inches	2 inches	1 -5/8 inches

This handout was developed by the Colorado Chapter of the International Code Council as a basic plan submittal under the 2021 International Residential Code. It is not intended to cover all circumstances. Check with your Department of Building Safety for additional requirements.

Single Family Residential Uncovered Decks and Porches

Table 2 - Wood Joist simple span

Maximum Live Load or Ground Snow Load 40psf, Maximum Dead Load 10psf
deflection L/360 Main span; L/180 cantilever

WOOD SPECIES grade # 2 or better	JOIST SIZE	MAXIMUM JOIST SPAN			MAXIMUM CANTILEVER		
		SPACING OF DECK JOISTS (inches)			SPACING OF DECK JOISTS WITH CANTILEVERS (inches)		
	Simple Span	12 on center	16 on center	24 on center	12 on center	16 on center	24 on center
Southern pine	2x6	9-11	9-0	7-7	1-3	1-4	1-6
	2x8	13-1	11-10	9-8	2-1	2-3	2-5
	2x10	16-2	14-0	11-5	3-4	3-6	2-10
	2x12	18-0	16-6	13-6	4-6	4-2	3-4
Douglas fir- larch, hem- fir, spruce-pine-fir	2x6	9-6	8-8	7-2	1-2	1-3	1-5
	2x8	12-6	11-1	9-1	1-11	2-1	2-3
	2x10	15-8	13-7	11-1	3-1	3-5	2-9
	2x12	18-0	15-9	12-10	4-6	3-11	3-3

Other Wood Species are subject to review by the Authority Having Jurisdiction (AHJ)

Table 3 - Wood Beam simple span

Maximum Live Load or Ground Snow Load 40psf, Maximum Dead Load 10psf
deflection L/360 Main span; L/180 cantilever

WOOD SPECIES grade #2 or better	SIZE	DECK JOIST SPAN (ft-in) LESS THAN OR EQUAL TO:						
		6	8	10	12	14	16	18
Southern pine	(2)-2x8	8-9	7-7	6-9	6-2	5-9	5-4	5-0
	(2)-2x10	10-4	9-0	8-0	7-4	6-9	6-4	6-0
	(2)-2x12	12-2	10-7	9-5	8-7	8-0	7-6	7-0
	(3)-2x8	10-10	9-8	8-6	7-9	7-2	6-8	6-4
	(3)-2x10	13-0	11-3	10-0	9-2	8-6	7-11	7-6
	(3)-2x12	15-3	13-3	11-10	10-9	10-0	9-4	8-10
Douglas fir-larch, hem-fir, spruce-pine-fir,	3 x 8 or (2)- 2 x 8	6-10	5-11	5-4	4-10	4-6	4-1	3-8
	3 x 10 or (2)- 2 x 10	8-4	7-5	6-6	5-11	5-6	5-1	4-8
	3 x 12 or (2)- 2 x 12	9-8	8-5	7-6	6-10	6-4	5-11	5-7
	4x6	6-5	5-6	4-11	4-6	4-2	3-11	3-5
	4x8	8-5	7-3	6-6	5-11	5-6	5-2	4-10
	4x10	9-11	8-7	7-8	7-0	6-6	6-1	5-8
	4 x12	11-5	9-11	8-10	8-1	7-6	7-0	6-7
	(3)-2x8	9-8	8-6	7-7	6-11	6-5	6-0	5-8
	(3)-2x10	12-0	10-5	9-4	8-6	7-10	7-4	6-11
	(3)-2x12	13-11	12-1	10-9	9-10	9-1	8-6	8-1

Other Wood Species are subject to review by the AHJ

Table 4 - Wood Post

Deck post size	Deck Wood Post Live Load 40 psf			
	4x4	4x6	6x6	8x8
Maximum height	6'-9"	8'	14'	14'

Use of engineered lumber is not covered by this guide.

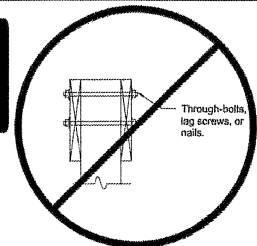

This handout was developed by the Colorado Chapter of the International Code Council as a basic plan submittal under the 2021 International Residential Code. It is not intended to cover all circumstances. Check with your Department of Building Safety for additional requirements.

Single Family Residential Uncovered Decks and Porches

Detail A

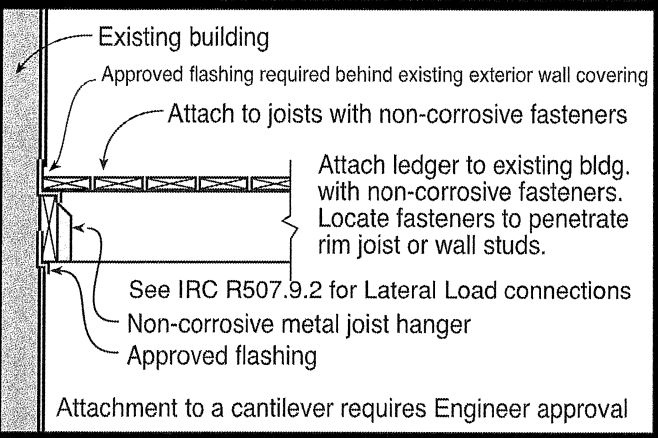

Detail B

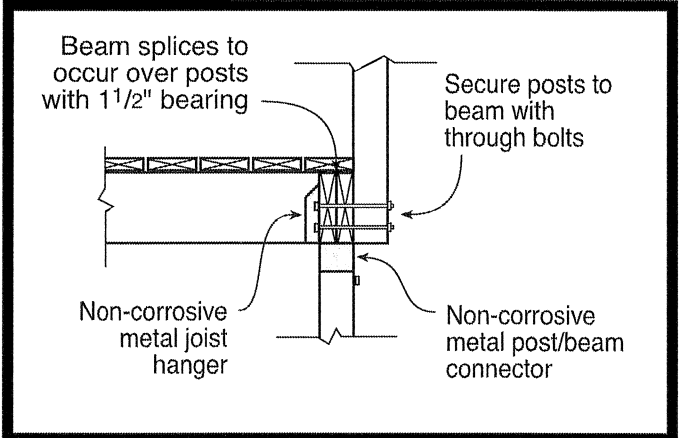

Alternate Detail B1

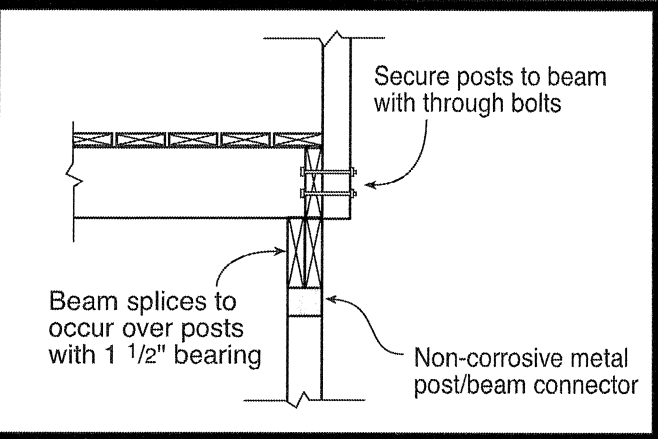

Alternate Detail B2

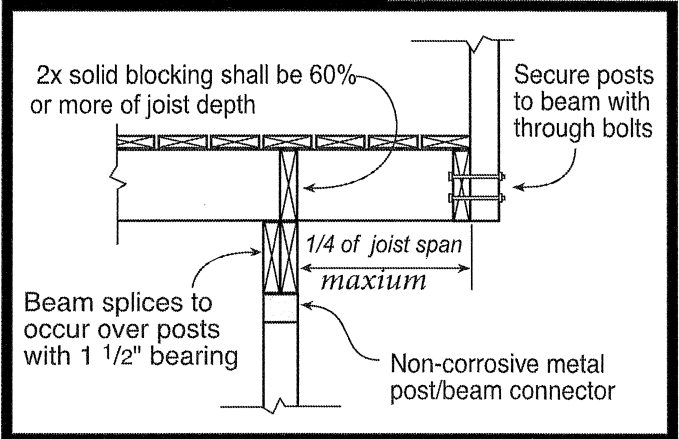

Detail C

Consult with your Local Jurisdiction for special connector requirements in high wind areas.

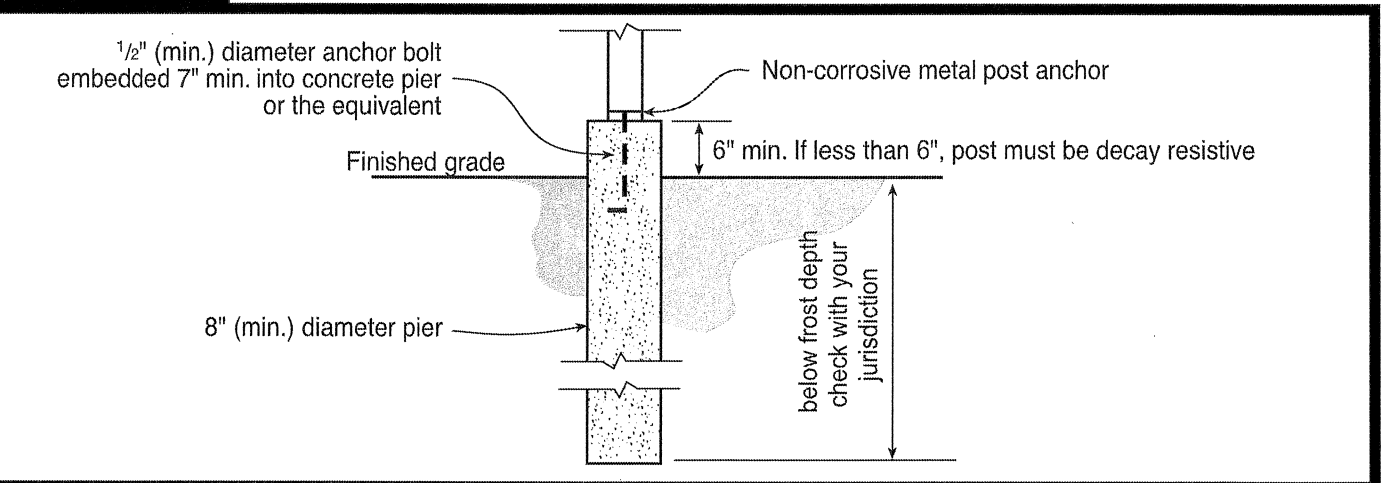

This handout was developed by the Colorado Chapter of the International Code Council as a basic plan submittal under the 2021 International Residential Code. It is not intended to cover all circumstances. Check with your Department of Building Safety for additional requirements.

Single Family Residential Uncovered Decks and Porches

Stair & Handrail Specifications

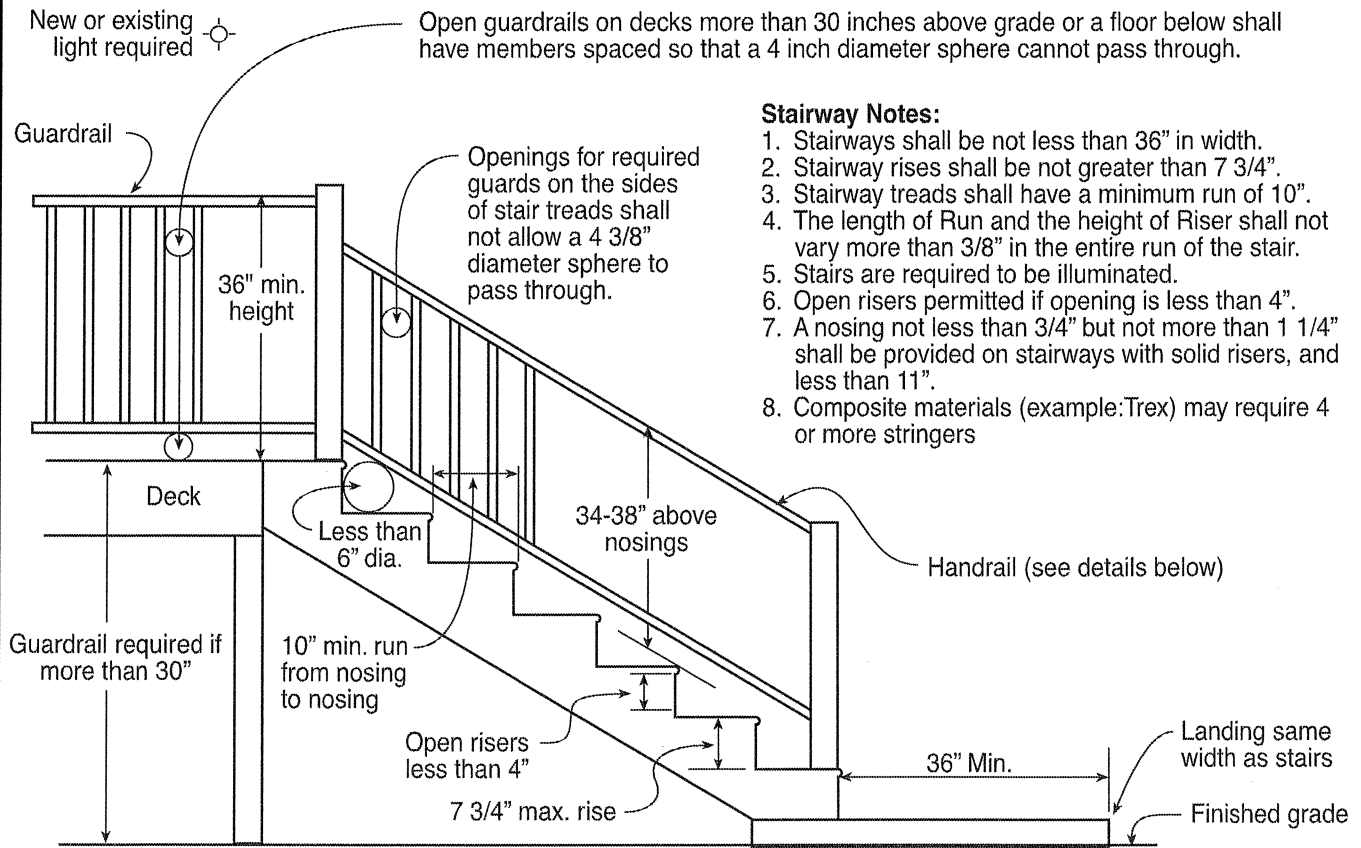

Stairway Notes:

1. Stairways shall be not less than 36" in width.
2. Stairway rises shall be not greater than 7 3/4".
3. Stairway treads shall have a minimum run of 10".
4. The length of Run and the height of Riser shall not vary more than 3/8" in the entire run of the stair.
5. Stairs are required to be illuminated.
6. Open risers permitted if opening is less than 4".
7. A nosing not less than 3/4" but not more than 1 1/4" shall be provided on stairways with solid risers, and less than 11".
8. Composite materials (example:Trex) may require 4 or more stringers

Handrail Notes:

1. Handrails shall be continuous on at least one side of stairs with 4 or more risers.
2. Top of the handrails shall be placed not less than 34 inches nor more than 38 inches above stair nosings.
3. The handgrip portion of handrails shall be not less than 1-1/4 inches nor more than 2 1/4 inches in cross section for non circular handrails.
4. Handrails shall be placed not less than 1-1/2 inches from any wall or other surface.
5. Handrails to be returned to wall, post or safety terminal (per 311.7.8.4 IRC)

Acceptable Handrail Details

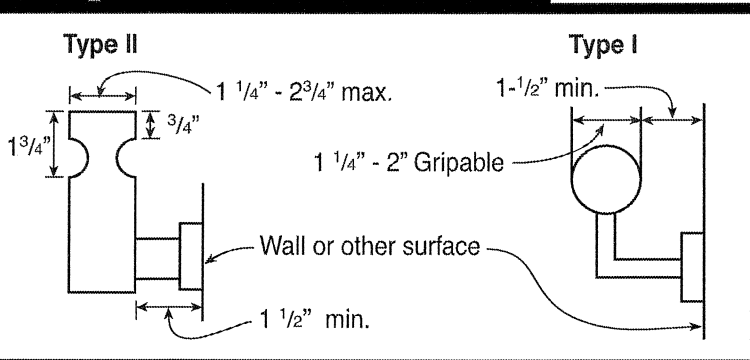

Unacceptable Handrails

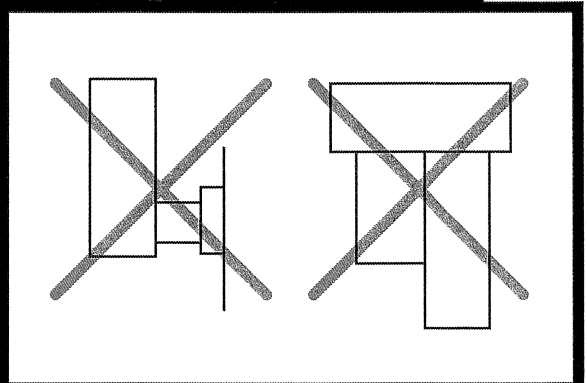

This handout was developed by the Colorado Chapter of the International Code Council as a basic plan submittal under the 2021 International Residential Code. It is not intended to cover all circumstances. Check with your Department of Building Safety for additional requirements.